

180FLIPTEK

180° Flip Up Conveyor

Machine Description

180FlipTek Fill Up Conveyor

Automatically flips any mattress up to 2.1m x 2.1m.

Comprising two powered conveyor belts, a large robust rotation motor/gearbox and pneumatically operated rear gate.

We offer numerous mattress flipping / 180° turn conveyor units, to accommodate any manufacturers need.

This machine will flip a mattress 180 degrees. Removing the need for two operators to flip the mattress.

We offer a comprehensive project management service supplying a full factory visualisation, tailored electrical controls, and bespoke machines to achieve the best possible solutions for all industries.

MATTRESSTEK are focused on high performance, only using leading suppliers and high-quality components to reduce downtime and improve efficiency.

MATTRESSTEK machines are designed to be maintenance friendly. Mechanical and electrical assemblies can be easily replaced and simply plugged in, reducing the need for an electrical/mechanical technician.

All MATTRESSTEK machines are designed, manufactured and built at our premises in the UK, by our team of experienced fabricators and machine builders.

For more information on any of our products please call 01282 479922 email us at: sales@mattresstek.co.uk or visit us at: www.mattresstek.co.uk

SERVICES AVAILABLE

Technical Support Installation and Setup

Bespoke Machine Designs

Maintenance

Parts

Hardware Support

Warranty and Lifetime Support

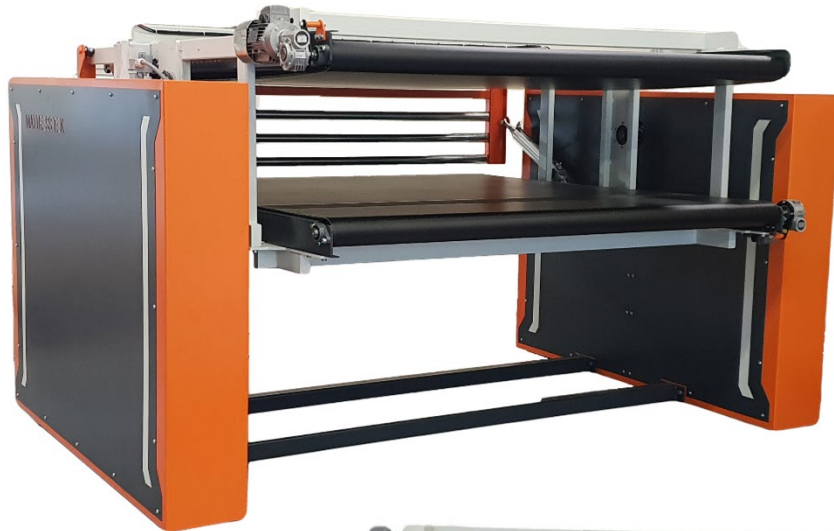

MATTRESSTEK
MACHINERY FOR THE MATTRESS INDUSTRY

Unit 3, Forest Mill, Burnley Road East, Rossendale
Lancashire, United Kingdom BB4 9BF
www.mattresstek.co.uk sales@mattresstek.co.uk
Tel +44 (0) 1282 479922

180FLIPTTEK

180° Flip Up Conveyor

Machine Features

- Removes the need for two operators to flip the mattress
- Designed to flawlessly merge with all of our other conveyors in our range
- Can be added onto any existing conveyor lines
- High quality specialised non-marking conveyor belt
- Efficient, reliable, high-speed conveyor
- Can be used on taped and non-taped products
- Low noise
- Full factory automation project management service available
- Full conveyor layout visualisation of your production line available to truly view and understand the conveyor line proposal
- Full electrical control circuit project management
- High quality motor drive
- Fully CE certified

Prior to shipment all machines are meticulously tested and trialled on customer samples.

For more information on any of our products please call 01282 479922 email us at: sales@mattresstek.co.uk or visit us at: www.mattresstek.co.uk

SERVICES AVAILABLE

- Technical Support Installation and Setup
- Bespoke Machine Designs
- Maintenance
- Parts
- Hardware Support
- Warranty and Lifetime Support

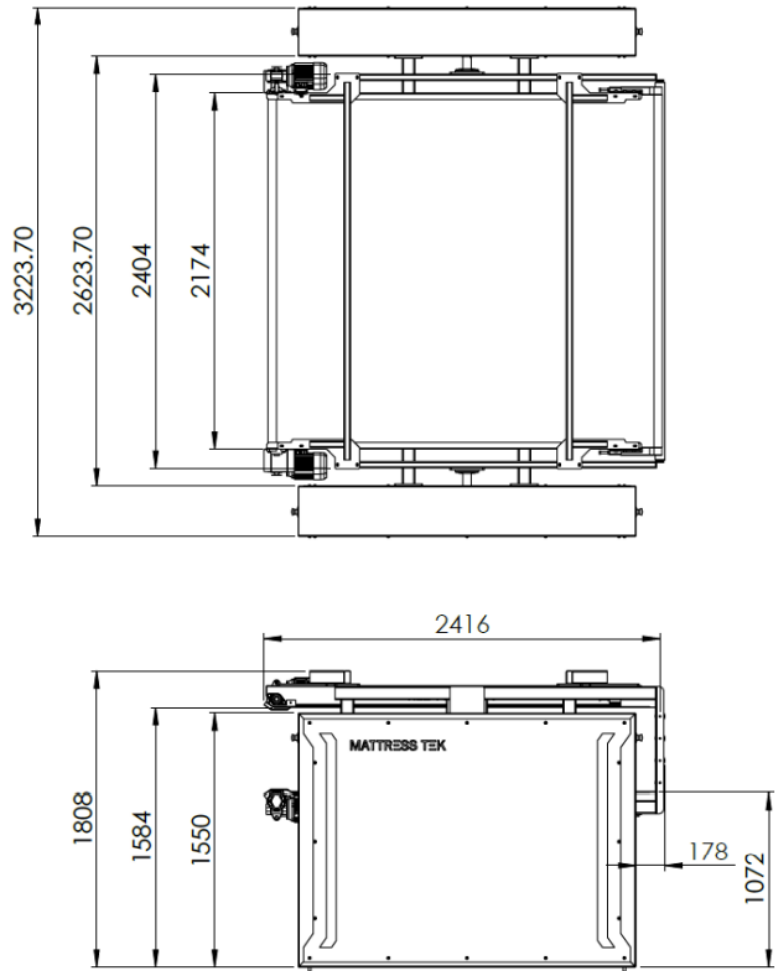

MACHINE TYPE	MACHINE HEIGHT	MACHINE LENGTH	MACHINE WIDTH	WEIGHT
180FLIPTTEKTEK - (Standard)	1808mm / 116"	3324mm / 232"	2416mm / 60"	600 - 700KG

OTHER SIZES AVAILABLE

ELECTRICAL REQUIREMENTS - TO CUSTOMER SPECIFICATION

AIR REQUIREMENTS - AIR REQUIRED 80PSI / 5.5Bar



Unit 3, Forest Mill, Burnley Road East, Rossendale
Lancashire, United Kingdom BB4 9BF
www.mattresstek.co.uk sales@mattresstek.co.uk
Tel +44 (0) 1282 479922