

HMTEK [HandleMakingMachine]

[MachineDescription]

HMTEK is a handle making machine which is fast, reliable, British made and with high quality components.

Features an HMI touch screen for ease of use, batch count facility and handle length input.

MATTRESSTEK are focused on high performance, only using leading suppliers and high-quality components to reduce downtime and improve efficiency.

MATTRESSTEK machines are designed to be maintenance friendly. Mechanical and electrical assemblies can be easily replaced and simply plugged in, reducing the need for an electrical/mechanical technician.

All MATTRESSTEK machines are designed, manufactured and built at our premises in the UK, by our team of experienced fabricators and machine builders.

Prior to shipment all machines are meticulously tested and trialed on customer samples.

For more information on any of our products please call 01282 479922 email us at: sales@mattresstek.co.uk or visit us at: www.mattresstek.co.uk

SERVICES AVAILABLE

Technical Support Installation and Setup
Bespoke Machine Designs
Maintenance
Parts
Hardware Support
Warranty and Lifetime Support



MATTRESSTEK
MACHINERY FOR THE MATTRESS INDUSTRY

Unit 3, Forest Mill, Burnley Road East, Rossendale
Lancashire, United Kingdom BB4 9PX
www.mattresstek.co.uk sales@mattresstek.co.uk
Tel: +44 (0)1282 479922

HMTEK [HandleMakingMachine]

[MachineLayout]

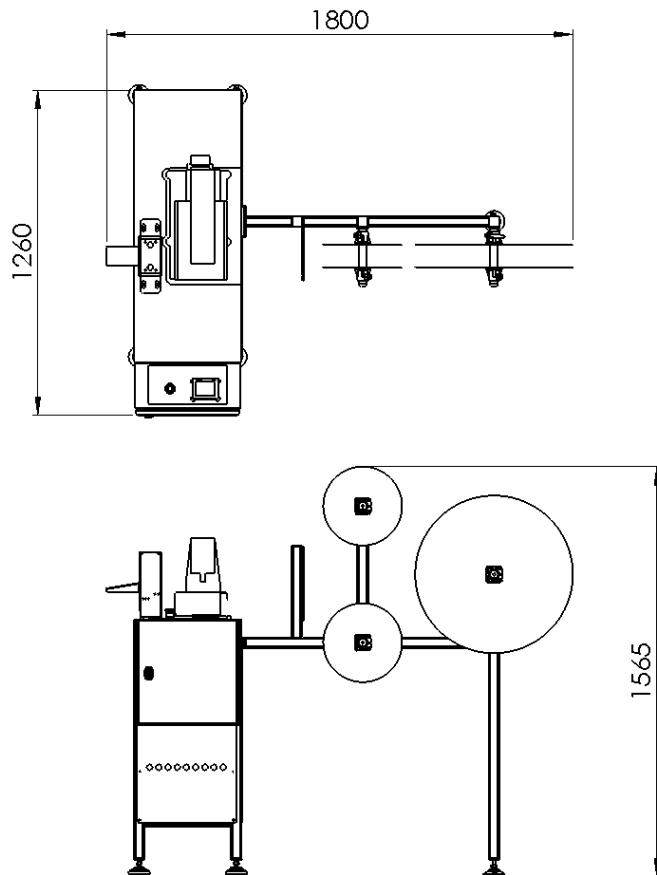

[MachineFeatures]

- 12 needles (3/16" gauge) OR 9 needles (1/4" gauge) - Sewing head
- Handle material and folder dims - material start width - 85mm - Handle finish width 58mm - stitch width 45mm
- Robust steel frame mounting.
- Purpose made material guide.
- Easy to use, simple HMI controls. With batch count facility.
- Steel in-feed frame.
- Fabric run out sensors for top & bottom ticking and filler material.
- Adjustable handle cut length. (by use of timer on HMI)
- Vertical Efficient cutting using a pneumatic cylinder from the top.
- Super quiet cutting.
- Can be fitted with a cutter or a rewind, or both. (optional)

[HMTEK Specification]

MACHINE TYPE	ELECTRICAL & AIR REQUIRMENTS
HMTEK	240V, single phase 16amp - Air required 80PSI / 5.5Bar

For more information on any of our products please call 01282 479922 email us at: sales@mattresstek.co.uk or visit us at: www.mattresstek.co.uk

SERVICES AVAILABLE

- Technical Support Installation and Setup
- Bespoke Machine Designs
- Maintenance
- Parts
- Hardware Support
- Warranty and Lifetime Support



MATTRESSTEK
MACHINERY FOR THE MATTRESS INDUSTRY

Unit 3, Forest Mill, Burnley Road East, Rossendale
Lancashire, United Kingdom BB4 9PX
www.mattresstek.co.uk sales@mattresstek.co.uk
Tel: +44 (0)1282 479922